

Dynamics of Glaciers

McCarthy Summer School 2012

Andy Aschwanden
Arctic Region Supercomputing Center
University of Alaska Fairbanks, USA

June 2012

Note: This script is largely based on the *Physics of Glaciers I* lecture notes by Martin Lüthi and Martin Funk, ETH Zurich, Switzerland and *Greve and Blatter* (2009).

1 Flow relation for polycrystalline ice

The most widely used flow relation for glacier ice is (*Glen, 1955; Steinemann, 1954*)

$$\dot{\epsilon}_{ij} = A\tau^{n-1}\sigma_{ij}^{(d)}. \quad (1)$$

with $n \sim 3$, and where $\dot{\epsilon}_{ij}$ and $\sigma_{ij}^{(d)}$ are the strain rate tensor and the deviatoric stress tensor, respectively. The rate factor $A = A(T)$ depends on temperature and other parameters like water content, impurity content and crystal size. The quantity τ is the second invariant of the deviatoric stress tensor. Several properties of Equation (1) are noteworthy:

- Elastic effects are neglected. This is reasonable if processes on the time scale of days and longer are considered.
- Stress and strain rate are collinear, i.e. a shear stress leads to shearing strain rate, a compressive stress to a compression strain rate, and so on.
- Only deviatoric stresses lead to deformation rates, isotropic pressure alone cannot induce deformation. Ice is an *incompressible* material (no volume change, except for elastic compression). This is expressed as

$$\dot{\epsilon}_{ii} = 0 \quad \iff \quad \frac{\partial v_x}{\partial x} + \frac{\partial v_y}{\partial y} + \frac{\partial v_z}{\partial z} = 0$$

- A *Newtonian viscous fluid*, like water, is characterized by the *viscosity* η

$$\dot{\epsilon}_{ij} = \frac{1}{2\eta} \sigma_{ij}^{(d)}. \quad (2)$$

By comparison with Equation (1) we find that viscosity of glacier ice is

$$\eta = \frac{1}{2A\tau^{n-1}}.$$

- Polycrystalline glacier ice is a *viscous fluid* with a **stress dependent viscosity** (or, equivalently, a strain rate dependent viscosity). Such a material is called a *non-Newtonian fluid*, or more specifically a *power-law fluid*.
- Polycrystalline glacier ice is treated as an *isotropic fluid*. No preferred direction (due to crystal orientation fabric) appears in the flow relation. This is a crude approximation to reality, since glacier ice usually is anisotropic, although to varying degrees.

Many alternative flow relations have been proposed that take into account the compressibility of firn at low density, the anisotropic nature of ice, microcracks and damaged ice, the water content, impurities and different grain sizes. Glen's flow law is still widely used because of its simplicity and ability to approximately describe most processes relevant to glacier dynamics at large scale.

1.1 Inversion of the flow relation

The flow relation of Equation (1) can be inverted so that stresses are expressed in terms of strain rates. Multiplying equation (1) with itself gives

$$\begin{aligned} \dot{\epsilon}_{ij} \dot{\epsilon}_{ij} &= A^2 \tau^{2(n-1)} \sigma_{ij}^{(d)} \sigma_{ij}^{(d)} && \text{(multiply by } \frac{1}{2}) \\ \underbrace{\frac{1}{2} \dot{\epsilon}_{ij} \dot{\epsilon}_{ij}}_{\dot{\epsilon}^2} &= A^2 \tau^{2(n-1)} \underbrace{\frac{1}{2} \sigma_{ij}^{(d)} \sigma_{ij}^{(d)}}_{\tau^2} \end{aligned}$$

where we have used the definition for the *effective strain rate* $\dot{\epsilon} = \dot{\epsilon}_e$, in analogy to the *effective shear stress* $\tau = \sigma_e$

$$\dot{\epsilon} = \sqrt{\frac{1}{2} \dot{\epsilon}_{ij} \dot{\epsilon}_{ij}}. \quad (3)$$

This leads to a relation between tensor invariants

$$\dot{\epsilon} = A\tau^n. \quad (4)$$

Coincidentally this is also the equation to describe simple shear, the most important part of ice deformation in glaciers

$$\dot{\epsilon}_{xz} = A\sigma_{xz}^{(d)n}. \quad (5)$$

Now we can invert the flow relation Equation (1)

$$\begin{aligned}\sigma_{ij}^{(d)} &= A^{-1} \tau^{1-n} \dot{\epsilon}_{ij} \\ \sigma_{ij}^{(d)} &= A^{-1} A^{\frac{n-1}{n}} \dot{\epsilon}^{-\frac{n-1}{n}} \dot{\epsilon}_{ij} \\ \sigma_{ij}^{(d)} &= A^{-\frac{1}{n}} \dot{\epsilon}^{-\frac{n-1}{n}} \dot{\epsilon}_{ij}.\end{aligned}\tag{6}$$

The above relation allows us to calculate the stress state if the strain rates are known (from measurements). Notice that only deviatoric stresses can be calculated. The mean stress (pressure) cannot be determined because of the incompressibility of the ice. Comparing Equation (6) with (2) we see that the shear viscosity is

$$\eta = \frac{1}{2} A^{-\frac{1}{n}} \dot{\epsilon}^{-\frac{n-1}{n}}.\tag{7}$$

Polycrystalline ice is a *strain rate softening* material: viscosity decreases as the strain rate increases.

Notice that the viscosity given in Equation (7) becomes infinite at very low strain rates, which of course is unphysical. One way to alleviate that problem is to add a small quantity η_0 to obtain a *finite viscosity*

$$\eta^{-1} = \left(\frac{1}{2} A^{-\frac{1}{n}} \dot{\epsilon}^{-\frac{n-1}{n}} \right)^{-1} + \eta_0^{-1}.\tag{8}$$

2 Simple stress states

To see what Glen flow law of Equation (1) describes, we investigate some simple, yet important stress states imposed on small samples of ice, e.g. in the laboratory.

a) Simple shear

$$\dot{\epsilon}_{xz} = A(\sigma_{xy}^{(d)})^3 = A\sigma_{xy}^3 \quad (9)$$

This stress regime applies near the base of a glacier.

b) Unconfined uniaxial compression along the vertical z -axis

$$\begin{aligned} \sigma_{xx} &= \sigma_{yy} = 0 \\ \sigma_{zz}^{(d)} &= \frac{2}{3}\sigma_{zz}; \quad \sigma_{xx}^{(d)} = \sigma_{yy}^{(d)} = -\frac{1}{3}\sigma_{zz} \\ \dot{\epsilon}_{xx} &= \dot{\epsilon}_{yy} = -\frac{1}{2}\dot{\epsilon}_{zz} = -\frac{1}{9}A\sigma_{zz}^3 \\ \dot{\epsilon}_{zz} &= \frac{2}{9}A\sigma_{zz}^3 \end{aligned} \quad (10)$$

This stress system is easy to investigate in laboratory experiments, and also applies in the near-surface layers of an ice sheet. The deformation rate is only 22% of the deformation rate at a shear stress of equal magnitude (Eq. 9).

c) Uniaxial compression confined in the y -direction

$$\begin{aligned} \sigma_{xx} &= 0; \quad \dot{\epsilon}_{yy} = 0; \quad \dot{\epsilon}_{xx} = -\dot{\epsilon}_{zz} \\ \sigma_{yy}^{(d)} &= \frac{1}{3}(2\sigma_{yy} - \sigma_{zz}) = 0; \quad \sigma_{yy} = \frac{1}{2}\sigma_{zz} \\ \sigma_{xx}^{(d)} &= -\sigma_{zz}^{(d)} = -\frac{1}{3}(\sigma_{yy} + \sigma_{zz}) = -\frac{1}{2}\sigma_{zz} \\ \dot{\epsilon}_{zz} &= \frac{1}{8}A\sigma_{zz}^3 \end{aligned} \quad (11)$$

This stress system applies in the near-surface layers of a valley glacier and in an ice shelf occupying a bay.

d) Shear combined with unconfined uniaxial compression

$$\begin{aligned}
\sigma_{xx} &= \sigma_{yy} = \sigma_{xy} = \sigma_{yz} = 0 \\
\sigma_{zz}^{(d)} &= \frac{2}{3}\sigma_{zz} = -2\sigma_{xx}^{(d)} = -2\sigma_{yy}^{(d)} \\
\tau^2 &= \frac{1}{3}\sigma_{zz}^2 + \sigma_{xz}^2 \\
\dot{\epsilon}_{zz} &= -2\dot{\epsilon}_{xx} = -2\dot{\epsilon}_{yy} = \frac{2}{3}A\tau^2\sigma_{zz} \\
\dot{\epsilon}_{xz} &= A\tau^2\sigma_{xz}
\end{aligned} \tag{12}$$

This stress configuration applies at many places in ice sheets.

3 Field equations

To calculate velocities in a glacier we have to solve *field equations*. For a mechanical problem (e.g. glacier flow) we need the *continuity of mass* and the *force balance equations*. The **mass continuity** equation for a compressible material of density ρ is (in different notations)

mass continuity

$$\frac{\partial \rho}{\partial t} + \frac{\partial(\rho u)}{\partial x} + \frac{\partial(\rho v)}{\partial y} + \frac{\partial(\rho w)}{\partial z} = 0 \tag{13a}$$

$$\frac{\partial \rho}{\partial t} + \nabla \cdot (\rho \mathbf{v}) = 0 \tag{13b}$$

If the density is homogeneous ($\frac{\partial \rho}{\partial x_i} = 0$) and constant (incompressible material $\frac{\partial \rho}{\partial t} = 0$) we get, in different, equivalent notations

$$\text{tr } \dot{\boldsymbol{\epsilon}} = \dot{\epsilon}_{ii} = 0 \tag{14a}$$

$$\nabla \cdot \mathbf{v} = v_{i,i} = 0 \tag{14b}$$

$$\dot{\epsilon}_{xx} + \dot{\epsilon}_{yy} + \dot{\epsilon}_{zz} = 0 \tag{14c}$$

$$\frac{\partial u}{\partial x} + \frac{\partial v}{\partial y} + \frac{\partial w}{\partial z} = 0 \tag{14d}$$

The **force balance** equation describes that all forces acting on a volume of ice, including the body force $\mathbf{b} = \rho \mathbf{g}$ (where \mathbf{g} is gravity), need to be balanced by forces acting on the sides of the volume. In compact tensor notation they read

force balance

$$\nabla \boldsymbol{\sigma} + \mathbf{b} = \mathbf{0}, \tag{15a}$$

The same equations rewritten in index notation (summation convention)

$$\sigma_{ij,j} + b_i = \frac{\partial \sigma_{ij}}{\partial x_j} + b_i = 0 \tag{15b}$$

and in full, unabridged notation

$$\begin{aligned}
 \frac{\partial \sigma_{xx}}{\partial x} + \frac{\partial \sigma_{xy}}{\partial y} + \frac{\partial \sigma_{xz}}{\partial z} + \rho g_x &= 0 \\
 \frac{\partial \sigma_{yx}}{\partial x} + \frac{\partial \sigma_{yy}}{\partial y} + \frac{\partial \sigma_{yz}}{\partial z} + \rho g_y &= 0 \\
 \frac{\partial \sigma_{zx}}{\partial x} + \frac{\partial \sigma_{zy}}{\partial y} + \frac{\partial \sigma_{zz}}{\partial z} + \rho g_z &= 0
 \end{aligned}
 \tag{15c}$$

These three equations describe how the body forces and boundary stresses are balanced by the stress gradients throughout the body.

Recipe

A recipe to calculate the flow velocities from given stresses, strain rates, symmetry conditions and boundary conditions

1. determine all components of the stress tensor σ_{ij} exploiting the symmetries, and using the flow law (1) or its inverse (6)
2. calculate the mean stress σ_m
3. calculate the deviatoric stress tensor $\sigma_{ij}^{(d)}$
4. calculate the effective shear stress (second invariant) τ
5. calculate the strain rates $\dot{\epsilon}_{ij}$ from τ and $\sigma_{ij}^{(d)}$ using the flow law
6. integrate the strain rates to obtain velocities
7. insert boundary conditions

4 Parallel sided slab

We calculate the velocity of a slab of ice resting on inclined bedrock. We assume that the inclination angle of surface α and bedrock β are the same. For simplicity we choose a coordinate system K that is inclined, i.e. the x -Axis is along the bedrock (Figure 1).

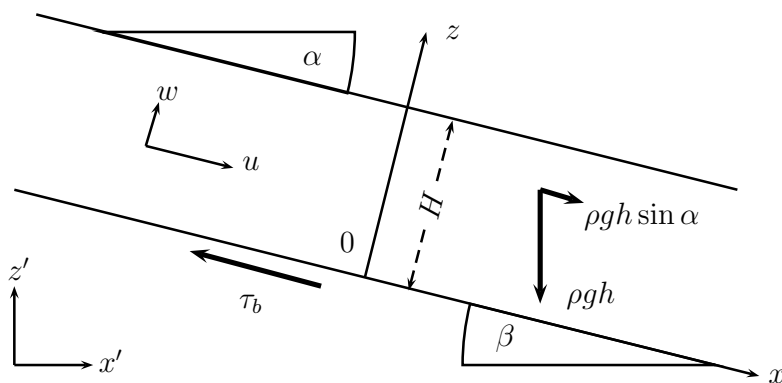

Figure 1: Inclined coordinate system for a parallel sided slab.

Body force In any coordinate system the body force (gravity) is $\mathbf{b} = \rho\mathbf{g}$. In the untilted coordinate system K' the body force is vertical along the $\hat{\mathbf{e}}'_3$ direction

$$\mathbf{b} = -\rho g \hat{\mathbf{e}}'_3. \quad (16)$$

The rotation matrix describes the transformation from K' to K

$$[a_{ij}] = \begin{pmatrix} \cos \alpha & 0 & -\sin \alpha \\ 0 & 1 & 0 \\ \sin \alpha & 0 & \cos \alpha \end{pmatrix} \quad (17)$$

and therefore

$$b_i = a_{ij} b'_j$$

with the components

$$\begin{aligned} b_1 &= a_{11} b'_1 + a_{12} b'_2 + a_{13} b'_3 \\ &= \cos \alpha \cdot 0 + 0 \cdot 0 - \sin \alpha (-g) \\ &= g \sin \alpha \\ b_2 &= 0 \\ b_3 &= -g \cos \alpha. \end{aligned}$$

Symmetry The problem has translational symmetry in the x and y direction. It follows that none of the quantities can change in these directions

$$\frac{\partial(\cdot)}{\partial x} = 0 \quad \text{and} \quad \frac{\partial(\cdot)}{\partial y} = 0. \quad (18)$$

Furthermore no deformation takes place in the y direction, i.e. all deformation happens in the x, z plane. This is called *plane strain* and leads to the constraints

$$\dot{\epsilon}_{yx} = \dot{\epsilon}_{yy} = \dot{\epsilon}_{yz} = 0. \quad (19)$$

Boundary conditions The glacier surface with the face normal $\hat{\mathbf{n}}$ is traction free

$$\boldsymbol{\Sigma}(\hat{\mathbf{n}}) \stackrel{!}{=} \mathbf{0} \iff \boldsymbol{\sigma}\hat{\mathbf{n}} \stackrel{!}{=} \mathbf{0} \iff \boldsymbol{\sigma} \begin{pmatrix} 0 \\ 0 \\ 1 \end{pmatrix} \stackrel{!}{=} \mathbf{0} \iff \begin{pmatrix} \sigma_{xz} \\ \sigma_{yz} \\ \sigma_{zz} \end{pmatrix} \stackrel{!}{=} \mathbf{0}. \quad (20)$$

The boundary conditions at the glacier base are $v_x = u_b$, $v_y = 0$ and $v_z = 0$.

Solution of the system We now insert all of the above terms into the field equations (14) and (15). The mass continuity equation (14d) together with (18) leads to

$$0 + 0 + \frac{\partial v_z}{\partial z} = 0. \quad (21)$$

The velocity component v_z is constant. Together with the boundary condition at the base ($v_z = 0$) we conclude that $v_z = 0$ everywhere.

Most terms in the momentum balance equation (15c) are zero, and therefore

$$\frac{\partial \sigma_{xz}}{\partial z} = -\rho g \sin \alpha, \quad (22a)$$

$$\frac{\partial \sigma_{yz}}{\partial z} = 0, \quad (22b)$$

$$\frac{\partial \sigma_{zz}}{\partial z} = \rho g \cos \alpha. \quad (22c)$$

Integration of Equation (22a) and (22c) with respect to z leads to

$$\sigma_{xz} = -\rho g z \sin \alpha + c_1,$$

$$\sigma_{zz} = \rho g z \cos \alpha + c_2.$$

The integration constants c_1 and c_2 can be determined with the traction boundary conditions (20) at the surface ($z_s = h$) and lead to

$$\sigma_{xz}(z) = \rho g(h - z) \sin \alpha, \quad (23a)$$

$$\sigma_{zz}(z) = -\rho g(h - z) \cos \alpha. \quad (23b)$$

We see that the stresses vary linearly with depth.

To calculate the deformation rates we exploit Glen's Flow Law (1), and make use of the fact that the strain rate components are directly related to the deviatoric stress components. Obviously we need to calculate the deviatoric stress tensor $\boldsymbol{\sigma}^{(d)}$. Because of the plain strain condition (Eq. 19) and the flow law, the deviatoric stresses in y -direction vanish $\sigma_{iy}^{(d)} = 0$. By definition $\sigma_{yy}^{(d)} = \sigma_{yy} - \sigma_m$ so that $\sigma_{yy} = \sigma_m$, where use has been made of the definition of the mean stress $\sigma_m := \frac{1}{3}\sigma_{ii} = \frac{1}{3}(\sigma_{xx} + \sigma_{yy} + \sigma_{zz})$.

Using again Glen's flow law we also see that (Eq. 18a)

$$\dot{\epsilon}_{xx} = \frac{\partial v_x}{\partial x} \stackrel{!}{=} 0 \quad \text{leads to} \quad \sigma_{xx}^{(d)} = 0 \quad \text{and} \quad \sigma_{xx} = \sigma_m.$$

Therefore all diagonal components of the stress tensor are equal to the mean stress $\sigma_m = \sigma_{xx} = \sigma_{yy} = \sigma_{zz} = -\rho g(h - z) \cos \alpha$ (using Eq. 23b). The effective stress τ can now be calculated with the deviatoric stress components determined above

$$\begin{aligned} \sigma_{xx}^{(d)} &= \sigma_{yy}^{(d)} = \sigma_{zz}^{(d)} = 0, \\ \sigma_{xy}^{(d)} &= \sigma_{yz}^{(d)} = 0, \\ \sigma_{xz}^{(d)} &= \rho g(h - z) \sin \alpha, \end{aligned}$$

so that

$$\tau^2 = \frac{1}{2} \sigma_{ij}^{(d)} \sigma_{ij}^{(d)} = \frac{1}{2} \left(2(\sigma_{xz}^{(d)})^2 \right) = (\sigma_{xz}^{(d)})^2. \quad (24)$$

With Equation (23a) we obtain

$$\tau = \left| \sigma_{xz}^{(d)} \right| = \rho g(h - z) \sin \alpha. \quad (25)$$

After having determined the deviatoric stresses and the effective stress, we can calculate the strain rates. The only non-zero term of the strain rate tensor is

$$\begin{aligned} \dot{\epsilon}_{xz} &= A \tau^{n-1} \sigma_{xz}^{(d)} = A (\rho g(h - z) \sin \alpha)^{n-1} \rho g(h - z) \sin \alpha \\ &= A (\rho g(h - z) \sin \alpha)^n. \end{aligned} \quad (26)$$

The velocities can be calculated from the strain rates

$$\dot{\epsilon}_{xz} = \frac{1}{2} \left(\frac{\partial v_x}{\partial z} + \frac{\partial v_z}{\partial x} \right)$$

where the second term vanishes. Integration with respect to z leads to

$$\begin{aligned} v_x(z) &= 2 \int_0^z \dot{\epsilon}_{xz}(z) dz \\ &= -\frac{2A}{n+1} (\rho g \sin \alpha)^n (h-z)^{n+1} + k \end{aligned}$$

With the boundary condition at the glacier base $v_x(0) = u_b$ we can determine the constant k as

$$k = \frac{2A}{n+1} (\rho g \sin \alpha)^n H^{n+1}$$

and finally arrive at the velocity distribution in a parallel sided slab

$$u(z) = v_x(z) = \underbrace{\frac{2A}{n+1} (\rho g \sin \alpha)^n (H^{n+1} - (h-z)^{n+1})}_{\text{deformation velocity}} + \underbrace{u_b}_{\text{sliding velocity}} \quad (27)$$

This equation is known as *shallow ice equations*, since it can be shown by rigorous scaling arguments that the longitudinal stress gradients $\frac{\partial \sigma_{xi}}{\partial x_i}$ and $\frac{\partial \sigma_{yi}}{\partial x_i}$ are negligible compared to the shear stress for shallow ice geometries such as the inland parts of ice sheets (except for the domes).

5 Flow through a cylindrical channel

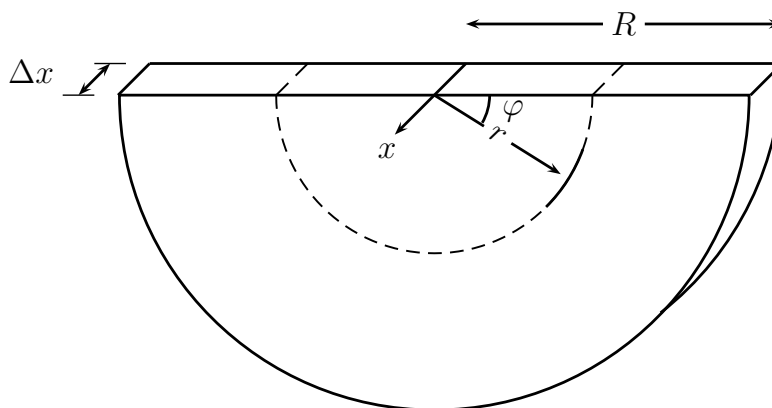

Figure 2: Coordinate system for a cross section through a valley glacier.

Most glaciers are not infinitely wide but flow through valleys. The valley walls exert a resistance, or drag on the glacier flow. To see how this alters the velocity field we consider

a glacier in a semi-circular valley of radius R and slope α . The body force from a slice has to be balanced by tractions acting on the circumference in distance r from the center (in a cylindrical coordinate system with coordinates x , r and φ)

$$\begin{aligned}\sigma_{rx}\pi r\Delta x &= -\rho g\frac{\pi r^2}{2}\Delta x\sin\alpha, \\ \sigma_{rx} &= -\frac{1}{2}r\rho g\sin\alpha.\end{aligned}\tag{28}$$

Since the only non-zero velocity component is in x -direction, most components of the strain rate tensor vanish. Under the assumption of no stress gradients in x -direction and equal shear stress along the cylindrical perimeter this leads to

$$\dot{\epsilon}_{rr} = \dot{\epsilon}_{xx} = \dot{\epsilon}_{\varphi\varphi} = 0 \quad \implies \quad \sigma_{rr}^{(d)} = \sigma_{xx}^{(d)} = \sigma_{\varphi\varphi}^{(d)} = 0 \tag{29}$$

$$\text{and also} \quad \sigma_{r\varphi}^{(d)} = \sigma_{x\varphi}^{(d)} = 0 \tag{30}$$

The second invariant of the deviatoric stress tensor is $\tau = |\sigma_{xr}| = \frac{1}{2}r\rho g\sin\alpha$. To calculate the velocity we use the flow law (1)

$$\frac{1}{2}\frac{du}{dr} = \dot{\epsilon}_{xr} = A\tau^{n-1}\sigma_{xr} = -A\left(\frac{1}{2}\rho g\sin\alpha\right)^n r^n$$

Integration with respect to r between the bounds 0 and R gives

$$u(0) - u(R) = v_x(0) - v_x(R) = 2A\left(\frac{1}{2}\rho g\sin\alpha\right)^n \frac{R^{n+1}}{n+1}.\tag{31}$$

The channel radius R is equivalent to the ice thickness H in Equation (27) and thus

$$u_{\text{def, channel}} = \left(\frac{1}{2}\right)^n u_{\text{def, slab}}.\tag{32}$$

The flow velocity on the center line of a cylindrical channel is **eight times slower** than in an ice sheet of the same ice thickness. For further reference we also write down the velocity at any radius

$$u(r) = u(0) - 2A\left(\frac{1}{2}\rho g\sin\alpha\right)^n \frac{r^{n+1}}{n+1}.\tag{33}$$

The ice flux through a cross section is (for $u_R = 0$)

$$\begin{aligned}q &= \int_0^R u(r)\pi r dr = u(0)\frac{\pi R^2}{2} - \frac{2A}{n+1}\left(\frac{1}{2}\rho g\sin\alpha\right)^n \pi \int_0^R r^{n+2} dr \\ &= u(0)\frac{\pi R^2}{2} - \frac{2}{n+3}u(0)\frac{\pi R^2}{2} \\ &= u(0)\frac{\pi R^2}{2}\left(1 - \frac{2}{n+3}\right) = u(0)\frac{\pi R^2}{2}\frac{n+1}{n+3}\end{aligned}\tag{34}$$

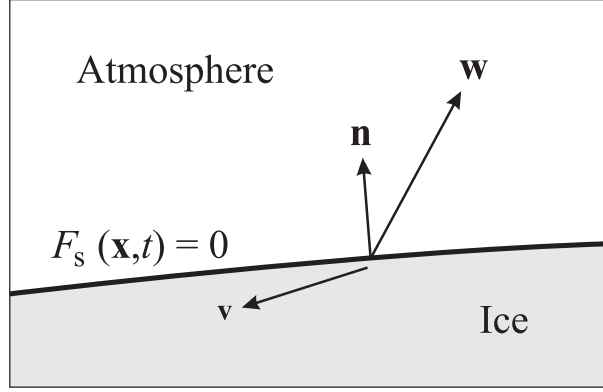

Figure 3: Geometry of the free surface $F_s(\mathbf{x}, t) = 0$. \mathbf{n} is the unit normal vector, \mathbf{v} is the ice velocity and \mathbf{w} the velocity of the free surface.

The mean velocity in the cross section is defined by $q = \bar{u} \frac{\pi R^2}{2}$ and is

$$\bar{u} = u(0) \frac{n+1}{n+3} \quad (35)$$

The mean velocity at the glacier surface is

$$\bar{u} = \frac{1}{R} \int_0^R u(r) dr = u(0) \frac{2A}{n+1} \left(\frac{1}{2} \rho g \sin \alpha \right)^n \frac{R^{n+1}}{n+2} = u(0) \frac{n+1}{n+2} \quad (36)$$

6 Free Surface

The free surface of a glacier can be regarded as a singular surface, given in implicit form by

$$F_s(\mathbf{x}, t) = z - h(x, y, t) = 0, \quad (37)$$

which can be interpreted as a zero-equipotential surface of the function $F_s(\mathbf{x}, t)$, with unit normal vector

$$\mathbf{n} = \frac{\nabla F_s}{|\nabla F_s|}, \quad (38)$$

which points into to atmosphere (Fig. 3), and $\nabla F_s = (-\partial h/\partial x, -\partial h/\partial y, 1)$. As a direct consequence of Eqn. (37), the time derivate of f_s following the motion of the free surface with velocity \mathbf{w} must vanish,

$$\frac{dF_s}{dt} = \frac{\partial F_s}{\partial t} + \mathbf{w} \cdot \nabla F_s = 0. \quad (39)$$

Let \mathbf{v} be the ice surface velocity, then we can introduce the ice volume flux through the free surface,

$$a_s^\perp = (\mathbf{w} - \mathbf{v}) \cdot \mathbf{n}, \quad (40)$$

which is the *accumulation-ablation function* or *surface mass balance*. The sign is chosen such that a supply (accumulation) is counted as positive and a loss (ablation) as negative. With this definition and Eqn. (38), Eqn. (39) can be rewritten as

$$\frac{\partial F_s}{\partial t} + \mathbf{v} \cdot \nabla F_s = -|\nabla F_s| a_s^\perp, \quad (41)$$

or, by inserting $F_s = z - h$,

$$\frac{\partial h}{\partial t} + v_x \frac{\partial h}{\partial x} + v_y \frac{\partial h}{\partial y} - v_z = -|\nabla F_s| a_s^\perp. \quad (42)$$

Since this condition has been derived by geometrical considerations only, it is called the *kinematic boundary condition*. Provided that the accumulation-ablation function is given, it evidently governs the evolution of the free surface.

In a similar manner to the upper free surface, a *kinematic boundary condition* for the ice base can be derived:

$$F_b(\mathbf{x}, t) = z - b(x, y, t) = 0, \quad (43)$$

and

$$\frac{\partial F_b}{\partial t} + \mathbf{v} \cdot \nabla F_b = -|\nabla F_b| a_b^\perp, \quad (44)$$

or, by inserting $F_b = z - b$,

$$\frac{\partial b}{\partial t} + v_x \frac{\partial b}{\partial x} + v_y \frac{\partial b}{\partial y} - v_z = |\nabla F_b| a_b^\perp. \quad (45)$$

Now, by combining the continuity equation (14d) with the kinematic boundary conditions (42) and (45), we can derive an evolution equation for the ice thickness $H(x, y, t) = h(x, y, t) - b(x, y, t)$. First we integrate (14d) from the ice base to the upper surface:

$$\int_b^h \left(\frac{\partial v_x}{\partial x} + \frac{\partial v_y}{\partial y} + \frac{\partial v_z}{\partial z} \right) dz \quad (46)$$

Using Leibnitz's rule and

$$\int_b^h \frac{\partial w}{\partial z} dz = w|_{z=h} - w|_{z=b} \quad (47)$$

we arrive at

$$\begin{aligned} \frac{\partial}{\partial x} \int_b^h v_x dz + \frac{\partial}{\partial y} \int_b^h v_y dz - v_x|_{z=h} \frac{\partial h}{\partial x} - v_y|_{z=h} \frac{\partial h}{\partial y} + v_z|_{z=h} \\ + v_x|_{z=b} \frac{\partial b}{\partial x} + v_y|_{z=b} \frac{\partial b}{\partial y} - v_z|_{z=b} = 0. \end{aligned} \quad (48)$$

With the kinematic boundary conditions (42) and (45), this yields

$$\frac{\partial (h - b)}{\partial t} + \frac{\partial}{\partial x} \int_b^h v_x dz + \frac{\partial}{\partial y} \int_b^h v_y dz - |\nabla F_s| a_s^\perp + |\nabla F_b| a_b^\perp = 0. \quad (49)$$

By introducing the *volume flux* \mathbf{Q} as the vertically-integrated horizontal velocity, that is

$$\mathbf{Q} = \begin{pmatrix} Q_x \\ Q_y \end{pmatrix} = \begin{pmatrix} \int_b^h v_x dz \\ \int_b^h v_y dz \end{pmatrix} = \bar{\mathbf{v}}H, \quad (50)$$

where $\bar{\mathbf{v}}$ is the depth-averaged velocity. We obtain

$$\frac{\partial H}{\partial t} = -\nabla \cdot \mathbf{Q} + |\nabla F_s|a_s^\perp - |\nabla F_b|a_b^\perp. \quad (51)$$

Recall that a_s^\perp and a_b^\perp are perpendicular to the free surface and the ice base. However, since $\frac{\partial H}{\partial t}$ refers to the vertical direction, we introduce $a_s = |\nabla F_s|a_s^\perp$ and $a_b = |\nabla F_b|a_b^\perp$, which are in the vertical direction (not shown, see *Greve and Blatter* (2009) for a derivation).

$$\frac{\partial H}{\partial t} = -\nabla \cdot \mathbf{Q} + a_s - a_b. \quad (52)$$

This is the ice thickness equation, which is the central evolution equation in glacier dynamics.

Literature

- Glen, J. W. (1955), The Creep of Polycrystalline Ice, *Proceedings of the Royal Society of London. Series A, Mathematical and Physical Sciences (1934-1990)*, 228(1175), 519–538, doi:10.1098/rspa.1955.0066.
- Greve, R., and H. Blatter (2009), *Dynamics of Ice Sheets and Glaciers*, Advances in Geophysical and Environmental Mechanics and Mathematics, Springer Verlag.
- Steinemann, S. (1954), Results of preliminary experiments on the plasticity of ice crystals, *J. Glaciol.*, 2, 404–416.